

## Bag closing machines of the SVT Series

Double-fold closure secured with sealing tape



**FTS**

- For double-fold closures secured with sealing tape on open paper bags, with or without plastic inner liners or respectively plastic inner-coatings
- Continuous operation for every line capacity
- The double-fold effectively reduces pressure on the inner seal
- Easy to operate and maintain thanks to good accessibility
- Tear-off strip applicator optional

Machine type  
FTS



Spreader-feeder (ASF)



Heating section for inner-liner sealing



Sealing tape application



Machine type FTS 1200 with ASF

Technical data

TYPE	HEATING SECTION
FTS	—
FTS 800	4 x 200 mm
FTS 1200	6 x 200 mm
FTS 1800	9 x 200 mm

Technical specifications

Length	2,700–5,400 mm
Width	1,080 mm
Height	1,910–2,610 mm
Weight	650–1,200 kg
Speed	10–22 metres/minute
Active output	0.37–0.55 kW
Heating output	1.4–9.5 kW
Bag width	160–650 mm

In the execution with the tear-off strip applicator, the length of the machine is 260 mm longer.

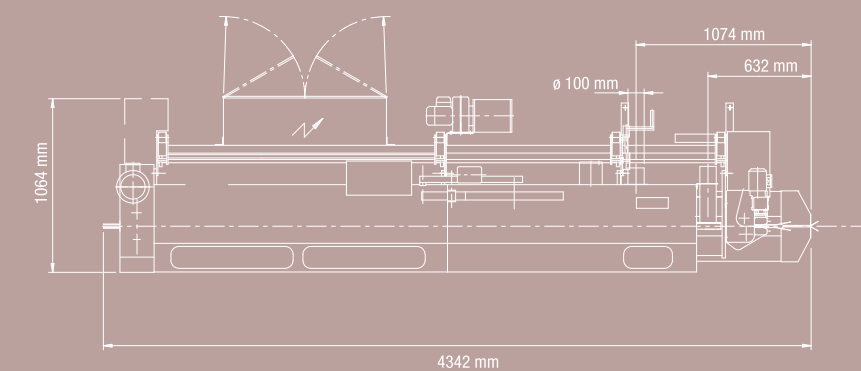

Top view of the machine type FTS

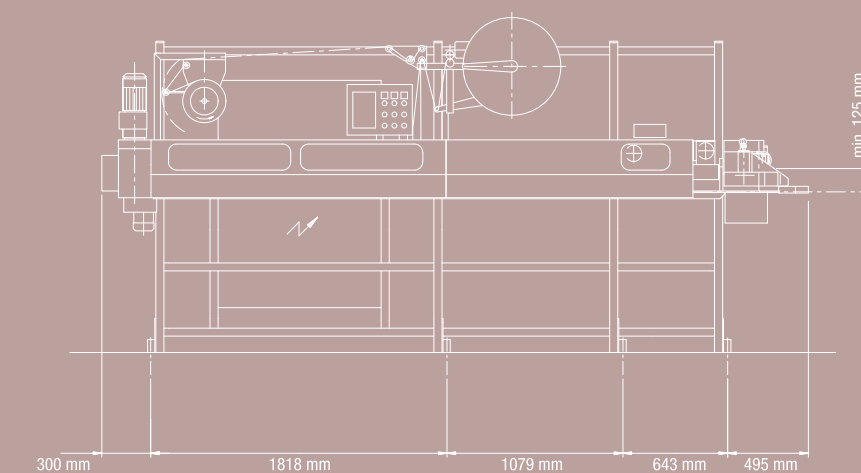

Side view of the machine type FTS



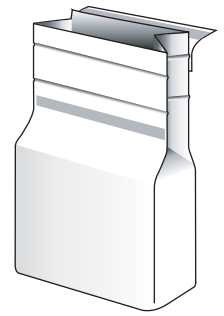
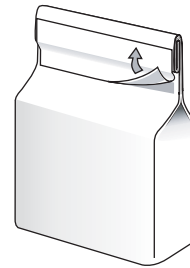
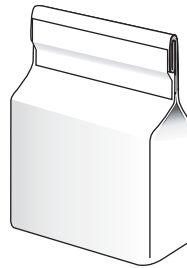

Closure in standard version

With the FTS bag closing machines, paper bags with or without plastic inner liners can be hermetically sealed.

Types of products

**Meypack**  
Verpackungssystemtechnik GmbH

Industriestraße 3  
D-48301 Nottuln-Appelhülsen  
Tel.: +49(0)2509-940  
Fax: +49(0)2509-948190  
info@meypack.de  
www.meypack.de